

SXV SERIES

NEW

125°C High Temperature, Lead Free Reflow Soldering.

◆ **FEATURES**

- Load Life : 125°C 1000 hours.
- Lead free reflow soldering is available.
- Available for high density mounting.



◆ **SPECIFICATIONS**

Items	Characteristics																																																								
Category Temperature Range	-40~+125°C																																																								
Rated Voltage Range	6.3~50V.DC																																																								
Capacitance Tolerance	±20%(20°C,120Hz)																																																								
Leakage Current(MAX)	I=0.01CV or 3µA whichever is greater. (After 2 minutes application of rated voltage) I=Leakage Current(µA) C=Rated Capacitance(µF) V=Rated Voltage(V)																																																								
Dissipation Factor(MAX)	<table border="1"> <tr> <td>Rated Voltage (V)</td> <td>6.3</td> <td>10</td> <td>16</td> <td>25</td> <td>35</td> <td>50</td> <td>(20°C, 120Hz)</td> </tr> <tr> <td rowspan="2">tanδ</td> <td>φ4~φ6.3</td> <td>0.35</td> <td>0.26</td> <td>0.20</td> <td>0.16</td> <td>0.14</td> <td>-</td> </tr> <tr> <td>φ8,φ10</td> <td>-</td> <td>0.35</td> <td>0.26</td> <td>0.20</td> <td>0.17</td> <td>0.15</td> </tr> </table>	Rated Voltage (V)	6.3	10	16	25	35	50	(20°C, 120Hz)	tanδ	φ4~φ6.3	0.35	0.26	0.20	0.16	0.14	-	φ8,φ10	-	0.35	0.26	0.20	0.17	0.15																																	
Rated Voltage (V)	6.3	10	16	25	35	50	(20°C, 120Hz)																																																		
tanδ	φ4~φ6.3	0.35	0.26	0.20	0.16	0.14	-																																																		
	φ8,φ10	-	0.35	0.26	0.20	0.17	0.15																																																		
Endurance	<p>After applying rated voltage with rated ripple current for 1000 hrs at 125°C, the capacitors shall meet the following requirements.</p> <table border="1"> <tr> <td>Capacitance Change</td> <td>Within ±30% of the initial value.</td> </tr> <tr> <td>Dissipation Factor</td> <td>Not more than 300% of the specified value.</td> </tr> <tr> <td>Leakage Current</td> <td>Not more than the specified value.</td> </tr> </table>	Capacitance Change	Within ±30% of the initial value.	Dissipation Factor	Not more than 300% of the specified value.	Leakage Current	Not more than the specified value.																																																		
Capacitance Change	Within ±30% of the initial value.																																																								
Dissipation Factor	Not more than 300% of the specified value.																																																								
Leakage Current	Not more than the specified value.																																																								
Low Temperature Stability Impedance Ratio(MAX)	<table border="1"> <tr> <td colspan="7">(φ4~φ6.3)</td> <td>(120Hz)</td> </tr> <tr> <td>Rated Voltage (V)</td> <td>6.3</td> <td>10</td> <td>16</td> <td>25</td> <td>35</td> <td></td> <td></td> </tr> <tr> <td>Z(-25°C)/Z(20°C)</td> <td>4</td> <td>3</td> <td>3</td> <td>2</td> <td>2</td> <td></td> <td></td> </tr> <tr> <td>Z(-40°C)/Z(20°C)</td> <td>12</td> <td>8</td> <td>6</td> <td>4</td> <td>4</td> <td></td> <td></td> </tr> <tr> <td colspan="7">(φ8,φ10)</td> <td>(120Hz)</td> </tr> <tr> <td>Rated Voltage (V)</td> <td>10</td> <td>16</td> <td>25</td> <td>35</td> <td>50</td> <td></td> <td></td> </tr> <tr> <td>Z(-25°C)/Z(20°C)</td> <td>8</td> <td>8</td> <td>4</td> <td>3</td> <td>3</td> <td></td> <td></td> </tr> </table>	(φ4~φ6.3)							(120Hz)	Rated Voltage (V)	6.3	10	16	25	35			Z(-25°C)/Z(20°C)	4	3	3	2	2			Z(-40°C)/Z(20°C)	12	8	6	4	4			(φ8,φ10)							(120Hz)	Rated Voltage (V)	10	16	25	35	50			Z(-25°C)/Z(20°C)	8	8	4	3	3		
(φ4~φ6.3)							(120Hz)																																																		
Rated Voltage (V)	6.3	10	16	25	35																																																				
Z(-25°C)/Z(20°C)	4	3	3	2	2																																																				
Z(-40°C)/Z(20°C)	12	8	6	4	4																																																				
(φ8,φ10)							(120Hz)																																																		
Rated Voltage (V)	10	16	25	35	50																																																				
Z(-25°C)/Z(20°C)	8	8	4	3	3																																																				

◆ **MULTIPLIER FOR RIPPLE CURRENT**

Frequency coefficient

Frequency (Hz)	60(50)	120	500	1k	10k≤
4.7~6.8µF	0.65	1.00	1.20	1.30	1.50
10~68µF	0.80	1.00	1.20	1.30	1.50
100~470µF	0.80	1.00	1.10	1.15	1.20

◆ **PART NUMBER**

SXV **DxL**
 Rated Voltage Series Rated Capacitance Capacitance Tolerance Option Case Size

◆ DIMENSIONS

(mm)

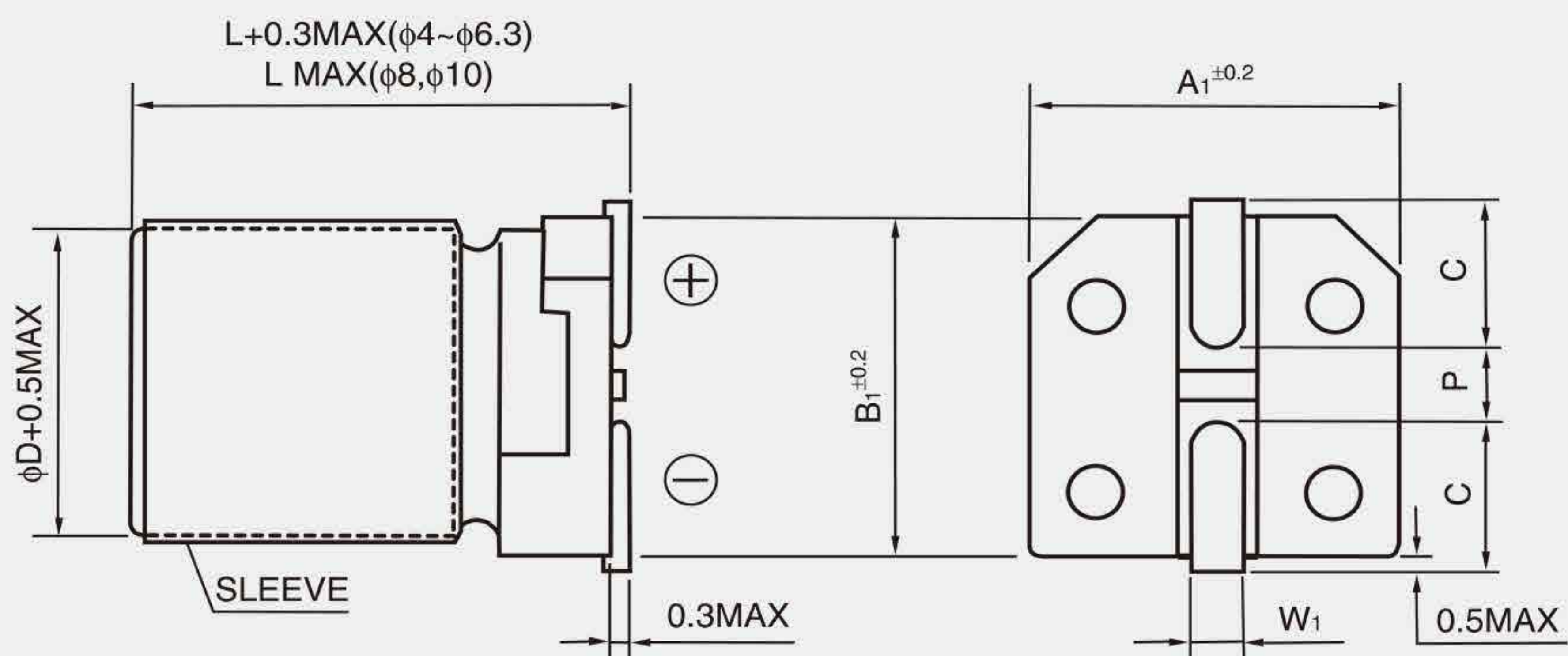

ϕD	L	A_1	B_1	C	W_1	P
4	7	4.3	4.3	2.0	0.5~0.8	0.8
5	7	5.3	5.3	2.2	0.5~0.8	1.3
6.3	7	6.6	6.6	2.7	0.5~0.8	1.8
8	10.5	8.3	8.3	2.9	0.8~1.1	3.1
10	10.5	10.3	10.3	3.2	0.8~1.1	4.5

◆ STANDARD SIZE, RATED RIPPLE CURRENT

Size $\phi D \times L$ (mm), Ripple Current (mA r.m.s./125°C, 120Hz)

WV(V.DC) Cap(μF)	6.3 (0J)		10 (1A)		16 (1C)		25 (1E)		35 (1V)		50 (1H)	
	Size	Ripple	Size	Ripple	Size	Ripple	Size	Ripple	Size	Ripple	Size	Ripple
4.7									4X7	14		
6.8							4X7	16				
10					4X7	18			5X7	22	8X10.5	35
15			4X7	19			5X7	24				
22	4X7	20			5X7	28			6.3X7	42	8X10.5	50
33			5X7	31			6.3X7	43	8X10.5	60	8X10.5 10X10.5	60 65
47	5X7	33			6.3X7	48	8X10.5	70	8X10.5 10X10.5	70 80	10X10.5	80
68			6.3X7	50								
100	6.3X7	51			8X10.5	95	8X10.5 10X10.5	95 110	10X10.5	110		
220			8X10.5	120	8X10.5 10X10.5	125 140	10X10.5	145				
330			8X10.5 10X10.5	135 160	10X10.5	165						
470			10X10.5	175								