

SS SERIES

85°C 7mm Height.

SS

105°C Version

MH7

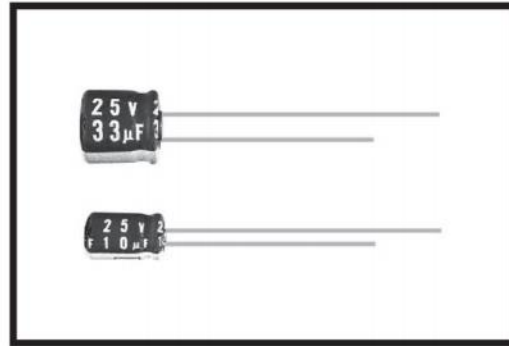

◆ SPECIFICATIONS

Items	Characteristics																											
Category Temperature Range	-40~+85°C																											
Rated Voltage Range	4~63V.DC																											
Capacitance Tolerance	±20%(20°C,120Hz)																											
Leakage Current(MAX)	I=0.01CV or 3µA whichever is greater. (After 2 minutes application of rated voltage) I= Leakage Current(µA) C=Rated Capacitance(µF) V=Rated Voltage(V)																											
Dissipation Factor(MAX)	<table border="1"> <thead> <tr> <th>Rated Voltage (V)</th> <th>4</th> <th>6.3</th> <th>10</th> <th>16</th> <th>25</th> <th>35</th> <th>50</th> <th>63</th> </tr> </thead> <tbody> <tr> <td>tanδ</td> <td>0.35</td> <td>0.24</td> <td>0.20</td> <td>0.17</td> <td>0.15</td> <td>0.13</td> <td>0.10</td> <td>0.10</td> </tr> </tbody> </table> (20°C, 120Hz)	Rated Voltage (V)	4	6.3	10	16	25	35	50	63	tanδ	0.35	0.24	0.20	0.17	0.15	0.13	0.10	0.10									
Rated Voltage (V)	4	6.3	10	16	25	35	50	63																				
tanδ	0.35	0.24	0.20	0.17	0.15	0.13	0.10	0.10																				
Endurance	After applying rated voltage with rated ripple current for 1000 hrs at 85°C, the capacitors shall meet the following requirements. <table border="1"> <tbody> <tr> <td>Capacitance Change</td> <td>Within ±20% of the initial value.</td> </tr> <tr> <td>Dissipation Factor</td> <td>Not more than 200% of the specified value.</td> </tr> <tr> <td>Leakage Current</td> <td>Not more than the specified value.</td> </tr> </tbody> </table>	Capacitance Change	Within ±20% of the initial value.	Dissipation Factor	Not more than 200% of the specified value.	Leakage Current	Not more than the specified value.																					
Capacitance Change	Within ±20% of the initial value.																											
Dissipation Factor	Not more than 200% of the specified value.																											
Leakage Current	Not more than the specified value.																											
Low Temperature Stability Impedance Ratio(MAX)	<table border="1"> <thead> <tr> <th>Rated Voltage (V)</th> <th>4</th> <th>6.3</th> <th>10</th> <th>16</th> <th>25</th> <th>35</th> <th>50</th> <th>63</th> </tr> </thead> <tbody> <tr> <td>Z(-25°C)/Z(20°C)</td> <td>7</td> <td>4</td> <td>3</td> <td>3</td> <td>2</td> <td>2</td> <td>2</td> <td>2</td> </tr> <tr> <td>Z(-40°C)/Z(20°C)</td> <td>15</td> <td>10</td> <td>8</td> <td>6</td> <td>4</td> <td>4</td> <td>4</td> <td>4</td> </tr> </tbody> </table> (120Hz)	Rated Voltage (V)	4	6.3	10	16	25	35	50	63	Z(-25°C)/Z(20°C)	7	4	3	3	2	2	2	2	Z(-40°C)/Z(20°C)	15	10	8	6	4	4	4	4
Rated Voltage (V)	4	6.3	10	16	25	35	50	63																				
Z(-25°C)/Z(20°C)	7	4	3	3	2	2	2	2																				
Z(-40°C)/Z(20°C)	15	10	8	6	4	4	4	4																				

◆ MULTIPLIER FOR RIPPLE CURRENT

Frequency coefficient

Frequency (Hz)	60(50)	120	500	1k	10k≤
0.1~1µF	0.50	1.0	1.20	1.30	1.50
2.2~4.7µF	0.65	1.0	1.20	1.30	1.50
10~47µF	0.8	1.0	1.20	1.30	1.50
100~470µF	0.8	1.0	1.10	1.15	1.20

◆ PART NUMBER

□□□
 Rated Voltage
 SS
 Series
 □□□□□
 Rated Capacitance
 □
 Capacitance Tolerance
 □□□
 Option
 □□
 Lead Forming
 DxL
 Case Size

◆ DIMENSIONS

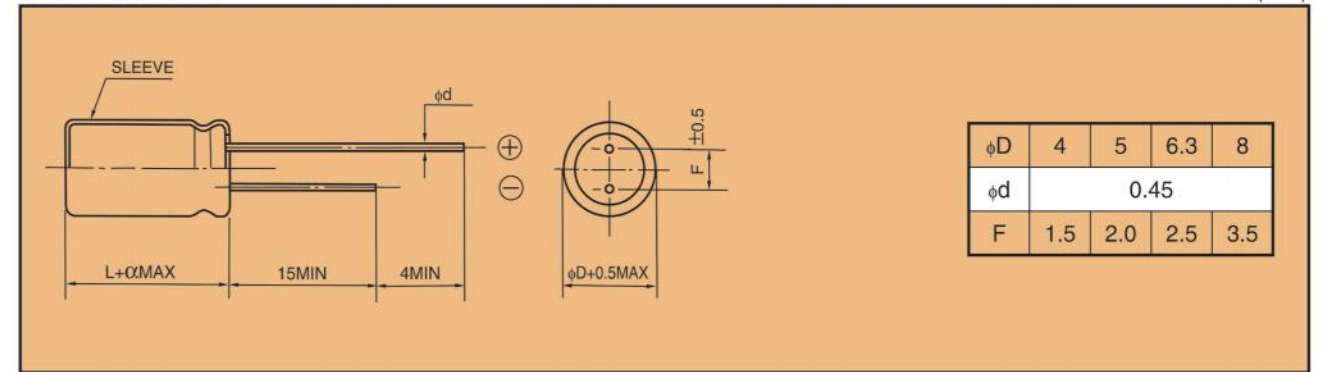

◆ STANDARD SIZE, RATED RIPPLE CURRENT

Size φDXL(mm), Ripple Current (mA r.m.s./85°C, 120Hz)

WV(V.DC)	4 (0G)		6.3 (0J)		10 (1A)		16 (1C)	
	Size	Ripple	Size	Ripple	Size	Ripple	Size	Ripple
Cap(µF)								
10							4X7	28
22			4X7	34	4X7	38	4X7	42
33	4X7	33	4X7	42	4X7	46	5X7	62
47	4X7	39	4X7	50	5X7	66	5X7	73
100	5X7	65	5X7	87	6.3X7	99	6.3X7	110
220	6.3X7	110	6.3X7	133	8X7	165	8X7	145
330	8X7	165	8X7	180	8X7	210		
470	8X7	190						

WV(V.DC)	25 (1E)		35 (1V)		50 (1H)		63 (1J)	
	Size	Ripple	Size	Ripple	Size	Ripple	Size	Ripple
Cap(µF)								
0.1					4X7	1.3	4X7	1.3
0.22					4X7	3.0	4X7	3.0
0.33					4X7	4.4	4X7	4.4
0.47					4X7	6.3	4X7	6.3
1					4X7	12	4X7	12
2.2					4X7	16	4X7	16
3.3			4X7	18	4X7	19	5X7	24
4.7	4X7	21	4X7	22	4X7	24	6.3X7	33
10	4X7	31	5X7	32	5X7	42	6.3X7	45
22	5X7	55	6.3X7	60	6.3X7	64		
33	6.3X7	66	6.3X7	73	8X7	75		
47	6.3X7	80	8X7	95	8X7	85		
100	8X7	115	8X7	115				